



EMERGENCY BATTERY SYSTEM – INTRODUCTION



EBS Battery Unit Only



Class I, Div. 1&2, Groups B[Ⓛ], C, D
 Class I, Zone 1&2, Groups IIB+H2[Ⓛ], IIA
 Class II, Div. 1&2, Groups EFG
 Class III
 Enclosure Type 4 (NEMA 4, 7B[Ⓛ] CD, 9EFG)

UL File LR11713

HOSTILE^{ITE} EBS

EMERGENCY

FEATURES-SPECIFICATIONS

Applications

Where required by the NEC (or local "Life Safety" code) for safe egress (over doors, aislaways, stairs, walkways, exit paths, and outer perimeter walls) to provide illumination during interruption of normal power to area lighting.

In indoor or outdoor locations made hazardous by the presence of flammable gas, vapors, or dusts. Includes refinery/chemical production and storage, grain processing, waste water treatment facilities and any area requiring heavy-duty dependable emergency lighting.

Exclusive Features

- LED Heads provide clear crisp illumination at 5000° Kelvin[Ⓛ]
- LED Head L70 value 100,000 hours for minimal maintenance
- Two head models up to 500% brighter than competitive conventional units[Ⓛ]
- Enclosure Type 4 (NEMA 4) for wet and harsh locations
- Group B is standard when using EBSHK type heads
- Automatic Safety Disconnect – Removing main cover disconnects battery power
- Ambient Suitability 0°C to 45°C Battery Unit; Heads to 55°
- Compact unit requires only two mounting points
- World Voltage 120-277 VAC 50/60Hz input

Other Features

- High % of lumens maintained during 90 minute egress cycle
- EBSHK type heads are fully adjustable on unit or remote when ordered with RFSL Factory Sealed mounting kits

- EBSEL type heads are factory sealed on their EZ type mounting boxes
- Heads can be remote mounted over 300' from battery unit
- Ni-Cad sealed batteries provide 90 minutes of illumination
- Integral base unit LED pilot light indicates AC power is present
- Choice of Integral or Remote Push-To-Test station to verify system operation
- Vapor Capsule to inhibit corrosion is standard with main enclosure unit
- Terminal Blocks identified for incoming and outgoing connections

Compliances

- UL 1598 Standard for Luminaires
- UL 8750 for LED Lighting
- UL 844 Luminaires for Hazardous Locations
- UL 1203 Explosion-Proof/Dust-Ignition-Proof Electrical Enclosures
- UL 924 Emergency Lighting
- CSA C22.2 no. 137-M1981 Luminaires for Hazardous Locations
- CSA C22.2 no. 30-M1986 C1D1 Enclosures
- CSA 22.2 no. 25-1066 C2D1 EFG Enclosures
- Enclosure Type 4
- NEMA 4, 7B[Ⓛ]CD, 9EFG

Materials

- Main Enclosure and Heads Copper Free Aluminum alloy with Baked Powder epoxy/polyester finish, electrostatically applied for complete, uniform corrosion protection
- Attachment fittings copper-free aluminum
- External hardware 316 Stainless Steel
- EBSEL reflectors EXIT accessory aluminum with white paint

Notes

- Ⓛ Main EBS unit is CID1 Grp B (Suitable Zone 1 IIB+H2) with attached EBSHK heads or no heads; with attached EBSEL heads unit is CID1 Groups CD (Suitable Zone 1 IIB, IIA)
- Ⓛ See VSL Series Photometry Color Graphs; 5000° Kelvin is typical ("sunlight")
- Ⓛ Based on published tungsten/incandescent data EBSEL Heads 300% brighter; EBSHK Heads 500% brighter



EBS Unit with HK Type Heads and Integral Push-To-Test



EBS Unit with EL Type Heads and Integral Push-To-Test



EBS Unit with EL Type Head and Exit plus HK Head with remote Push-To-Test



EMERGENCY BATTERY SYSTEM – LOGIC & COMPONENTS

| Catalog Number Logic | | EBS23DH | - | P | T | A | D |
|----------------------------------|---|---------|---|---|---|---|---|
| EBS23DH | Series Constant 120-277V 50/60Hz 23W | | | | | | |
| | Dual-Head (Remote or Attached) | | | | | | |
| Test Options | | | | | | | |
| P | Push-To-Test on Enclosure | | | | | | |
| R | Remote Push-To-Test Station (EBS-PTT shipped separately) | | | | | | |
| N | None - ordered separately or breaker controlled | | | | | | |
| Time Delay Option | | | | | | | |
| T | Power Resumption Emergency Time-delay (Factory set approx. 15 min.) 120 thru 277V | | | | | | |
| N | No Time-Delay | | | | | | |
| Luminaire Head Options ①② | | | | | | | |
| N | No heads - For Remote Heads Ordered Separately | | | | | | |
| A | 2 EBSHK1030 Heads Factory Attached | | | | | | |
| B | 2 EBSEL1030 Heads (Less Guards) and Fittings for Attachment | | | | | | |
| BG | 2 EBSEL1030 Heads with Guards and Fittings for Attachment | | | | | | |
| BE | 2 EBSEL1030 Heads with 1 Guard and 1 HEXA-100 EXIT and Fittings for Attachment | | | | | | |
| C | 1 EBSHK1030 Head Attached and 1 EBSEL1030 Head (Less Guard) and Fittings for Attachment | | | | | | |
| CG | 1 EBSHK1030 Heads Attached and 1 EBSEL1030 Head with Guard and Fittings for Attachment | | | | | | |
| CE | 1 EBSHK1030 Heads Attached and 1 EBSEL1030 Head with HEXA-100 EXIT and Fittings for Attachment | | | | | | |
| D | 1 EBSHK1030 Only (2nd Head Remote - Ordered Separately) | | | | | | |
| E | 1 EBSEL1030 Only Less Guard and Fittings for Attachment (2nd Head Remote - Ordered Separately) | | | | | | |
| EG | 1 EBSEL1030 Only with Guard and Fittings for Attachment (2nd Head Remote - Ordered Separately) | | | | | | |
| EE | 1 EBSEL1030 Only with HEXA100 EXIT and Fittings for Attachment (2nd Head Remote - Ordered Separately) | | | | | | |
| Drain ③ | | | | | | | |
| D | Group B Drain for Wet Applications including condensation from heat <-> cold cycling | | | | | | |
| Blank | Not included | | | | | | |

① Main Enclosure nameplate does not reflect heads ordered; unit is Dual Marked with ratings dependent on heads attached. E.g. if No heads or EBSHK only head(s) attached then unit is C1D1 Groups BCD; if an EBSEL head is attached then unit is Groups CD.

② Units ordered with EBSHK heads are shipped with heads attached; EBSEL heads are shipped separately.

③ Drain packed in enclosure with vapor capsule.



Factory Sealed Remote LED Spot Light - Bottom Feed



Factory Sealed Remote LED Spot Light - Side Feed



Remote Push-To-Test Station



Remote LED Luminaire

EBS UNIT - BOTTOM DETAIL



- A Optional Push-To-Test
- B Optional Group B Drain
- C Standard Pilot Light
- D Entry for Remote P-T-T Station
- E Power Entry (also on top)

The EBS23 System is designed to power 2 Heads for operation (total attached or remote); each Head is approximately 30VDC, 10 Watts.



EMERGENCY BATTERY SYSTEM – PRE-CONFIGURED UNITS



LED
TECHNOLOGY

Class I, Div. 1&2, Groups B¹,C,D
Class I, Zone 1&2, Groups IIB+H2¹, IIA
Class II, Div. 1&2, Groups EFG
Class III
Enclosure Type 4 (NEMA 4, 7B¹ CD, 9EFG)

File LR11713

ORDERING INFORMATION

| Integral Push-To-Test | | Remote Push-To-Test | |
|---|---|---|--|
| EBS System with Two EBSHK Heads ②③ CID1BCD | | | |
| Integral PTT, Two EBSHK | Integral PTT, TDR , Two EBSHK | Remote PTT, Two EBSHK | Remote PTT, TDR , Two EBSHK |
| EBS23DH-PNA | EBS23DH-PTA | EBS23DH-RNA | EBS23DH-RTA |
| EBS System with Two EBSEL Heads with Guards ②③ CID1CD | | | |
| Integral PTT, Two EBSEL Heads w/ Guards | Integral PTT, TDR , Two EBSEL Heads w/Guards | Remote PTT, Two EBSEL Heads w/Guards | Remote PTT, TDR , Two EBSEL Heads w/Guards |
| EBS23DH-PNBG | EBS23DH-PTBG | EBS23DH-RNBG | EBS23DH-RTBG |
| EBS System with One EBSHK Head & 1 EBSEL Head with Guard ②③ CID1CD | | | |
| Integral PTT, One EBSHK & One EBSEL Head w/Guard | Integral PTT, TDR , One EBSHK & One EBSEL Head w/Guard | Remote PTT, One EBSHK & One EBSEL Head w/Guard | Remote PTT, TDR , One EBSHK & One EBSEL Head w/Guard |
| EBS23DH-PNCG | EBS23DH-PTCG | EBS23DH-RNCG | EBS23DH-RTCG |
| EBS System with Two EBSEL Heads One with EXIT ②③ CID1CD | | | |
| Integral PTT, Two EBSEL Heads, One w/EXIT, One w/ Guard | Integral PTT, TDR , Two EBSEL Heads One w/EXIT, One w/Guard | Remote PTT, Two EBSEL Heads, One w/EXIT, One w/Guard | Remote PTT, Two EBSEL Heads, One w/EXIT, One w/Guard |
| EBS23DH-PNBE | EBS23DH-PTBE | EBS23DH-RNBE | EBS23DH-RTBE |
| EBS System with One EBSHK Head & One EBSEL Head with EXIT ②③ CID1CD | | | |
| Integral PTT, One EBSHK Head, One EBSEL w/EXIT | Integral PTT, TDR , One EBSHK Head, One EBSEL w/EXIT | Remote PTT, One EBSHK Head, One EBSEL w/EXIT | Remote PTT, TDR , One EBSHK Head, One EBSEL w/EXIT |
| EBS23DH-PNCE | EBS23DH-PTCE | EBS23DH-RNCE | EBS23DH-RTCE |
| EBS System Only for Remote Heads (order two separately) ②③ CID1BCD | | | |
| Integral PTT, No Heads | Integral PTT, TDR , No Heads | Remote PTT, No Heads | Remote PTT, TDR , No Heads |
| EBS23DH-PNN | EBS23DH-PTN | EBS23DH-RNN | EBS23DH-RTN |



① Main EBS unit is CID1 Group B (Suitable Zone 1 IIB+H2) with attached EBSHK heads or no heads; with attached EBSEL heads unit is CID1 Groups CD (Suitable Zone 1 IIB, IIA)

② Use catalog logic for single attached head models and order required remote 2nd head separately. Note, for EXIT applications EBSEL heads must be ordered without guards.

③ PTT = Push-To-Test; TDR = Time Delay Relay (prox 15 minutes after power resumption).

LIGHTING

EBS SERIES



EMERGENCY BATTERY SYSTEM – REMOTE HEADS & ACCESSORIES



EBSEL Shown with Exit Accessory

| EBSEL1030 REMOTE HEADS WITH MOUNT (FACTORY SEALED) | | | | CID1CD; C2D1EFG |
|--|---------------|---------------|--------------|-------------------|
| 10W 30VDC | PENDANT 3/4"① | CEILING 3/4"① | WALL 3/4"① | STANCHION 1-1/2"② |
| With Guard | EBSEL1030A2G | EBSEL1030X2G | EBSEL1030B2G | EBSEL1030D4G |
| Without Guard③ | EBSEL1030A2 | EBSEL1030X2 | EBSEL1030B2 | EBSEL1030D4 |

| EBSEL1030 COMPONENTS & ACCESSORIES – DESCRIPTION | CATALOG NUMBER |
|--|----------------|
| EBSEL 10W 30V Head Only with LED's, Less Mount and Guard | EBSEL1030 |
| Guard | EMG1 |
| Red Guard – used to signify remote fixture is for Emergency | EMG1-R④ |
| EXIT Accessory – 3-sided white painted aluminum | HEXA-100④ |
| Dome Reflector | ERSD15 |
| Angle Reflector | ERA15 |
| Sealed Fittings Set for attachment of Pendant EBSEL to EBS23HD-xxx | EBS-AHFS |
| Replacement Globe and Support Assembly | EMGS1 |



EBSEL1030



EMG1



EMG1-R



ERSD15



ERA15



EMGS1



| MOUNTING BOXES | | | | |
|----------------|---------|---------|-----------|-----------------|
| CATALOG NUMBER | | | | HUB SIZE |
| PENDANT | CEILING | BRACKET | STANCHION | |
| EZA2 | EZX2 | EZB2 | - | 3/4" |
| EZA3 | EZX3 | EZB3 | - | 1" |
| - | - | - | EZD4④ | 1-1/4" / 1-1/2" |

- ① For 1" pendant, ceiling and wall hubs, substitute "3" for "2" in catalog number; example: EBSEL1030A3G.
- ② Stanchion conduit hub size supplied is 1-1/2" with 1-1/2" to 1-1/4" reducer for 1-1/4" mounting.
- ③ Order fixture without guard for use with HEXA-100 EXIT Accessory, or to order EMG1-R Red Guard.
- ④ For EBSEL with Mount Dimensions, see EMI15 series in lighting section.

| EBSHK1030 10W 30V HEADS, COMPONENTS & ACCESSORIES | | CID1BCD; C2D1EFG |
|--|----------------|------------------|
| DESCRIPTION | CATALOG NUMBER | |
| EBSHK Head Only with LED's – Requires Field Seal① | EBSHK1030 | |
| EBSHK Head with ADJUSTABLE FACTORY SEALED "C" fittings set | EBSHK1030-RFSC | |
| EBSHK Head with ADJUSTABLE FACTORY SEALED "L" fittings set | EBSHK1030-RFSL | |
| Sealed Fittings Set for attachment of EBSHK to EBS23DH-xxx | EBS-AHFS | |

① Seal purchased separately appropriate of area of use

| EBS23DH SERIES ACCESSORIES – DESCRIPTION | CATALOG NUMBER |
|---|----------------|
| Remote Push-To-Test Station Group B 3/4" Feed-Thru w/Close Up Plug① | EBS-PTT |
| Remote Push-To-Test Station with Lock Off, Group B 3/4" Feed-Thru① | EBS-PTT-LO |
| Lock-Off for Integral Push-To-Test | G010502 |
| Sealed Fittings Set for attachment of EBSHK to GEBC-2 or GEBL-2 | EBS-AHFS |
| Replacement Battery Pack and Electronics | KLBP01 |
| Replacement Vapor Capsule for corrosion protection | EBS-VC |

① EBS23DH requires conduit seals (purchased separately) exiting enclosure within 18"; EBS-PTT contains a N.C. contact and is Factory Sealed for C&D and up to 5' for Group B.



EBSHK1030



EBSHK1030-RFSL



EBSHK1030-RFSC



EBS-PTT



EMERGENCY BATTERY SYSTEM – ELECTRICAL & TEMPERATURE DATA

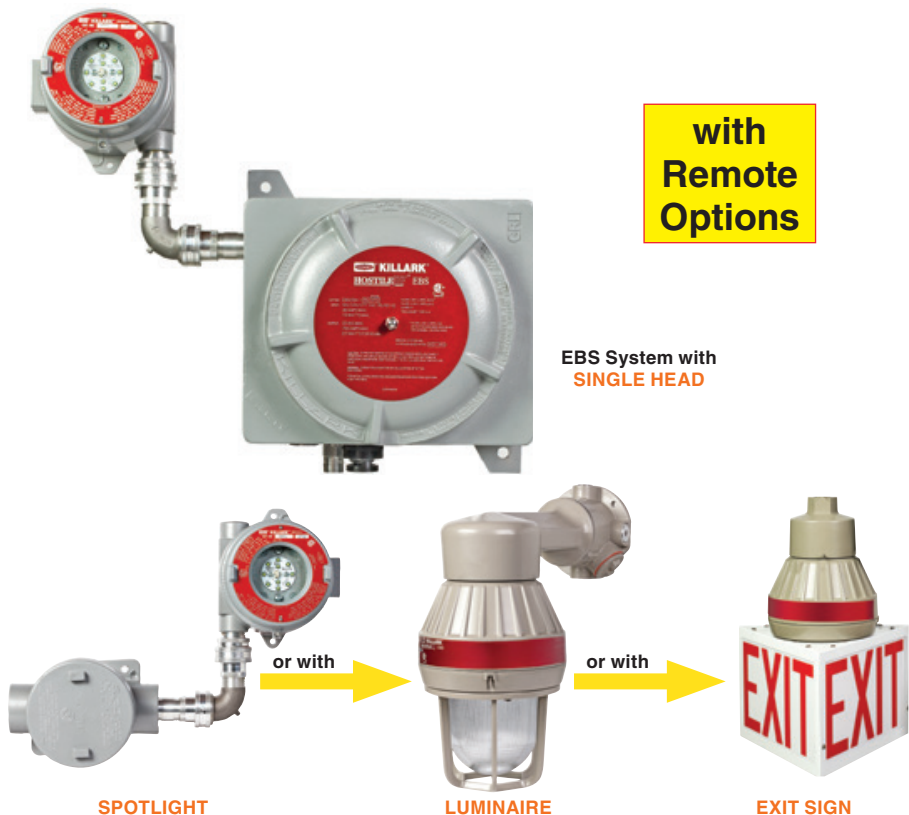

with
Remote
Options

EBS System with
SINGLE HEAD

SPOTLIGHT

LUMINAIRE

EXIT SIGN

LED 10W EBSHK1030



ZONAL LUMEN SUMMARY

| ZONE | LUMENS | FIXT% |
|--------|--------|--------|
| 0-30 | 254 | 27.9% |
| 0-40 | 423 | 46.3% |
| 0-60 | 781 | 85.5% |
| 0-90 | 913 | 100.0% |
| 90-120 | 0 | 0.0% |
| 90-130 | 0 | 0.0% |
| 90-150 | 0 | 0.0% |
| 90-180 | 0 | 0.0% |
| 0-180 | 913 | 100.0% |

Absolute Photometry
Total Luminaire Efficiency = N.A.%
Spacing to Mounting Height Ratio 2.1

EMERGENCY MODE LUMENS

| | | | |
|---------|-------|-----|--------|
| 05 Min. | 99.1% | 905 | Lumens |
| 45 Min. | 99.4% | 871 | Lumens |
| 90 Min. | 95.3% | 871 | Lumens |

LED 10W EBSEL1030



ZONAL LUMEN SUMMARY

| ZONE | LUMENS | FIXT% |
|--------|--------|-------|
| 0-30 | 180 | 16.7% |
| 0-40 | 344 | 31.8% |
| 0-60 | 758 | 70.1% |
| 0-90 | 1067 | 98.7% |
| 90-120 | 11 | 1.0% |
| 90-130 | 13 | 1.2% |
| 90-150 | 14 | 1.3% |
| 90-180 | 14 | 1.3% |
| 0-180 | 1081 | 100% |

Absolute Photometry
Total Luminaire Efficiency = N.A.%
Spacing to Mounting Height Ratio 2.1

EMERGENCY MODE LUMENS

| | | |
|---------|-------|------------|
| 5 Min. | 94.4% | 102 Lumens |
| 45 Min. | 91.3% | 987 Lumens |
| 90 Min. | 89.3% | 966 Lumens |

EBS23DH ELECTRICAL DATA

| CATALOG NUMBER | INPUT** | | | OUTPUT** | | |
|----------------|------------|-------|---------|----------|-------|---------|
| | VOLTAGE | WATTS | CURRENT | VOLTAGE | WATTS | CURRENT |
| EBS23DH | 120-277VAC | 7.5 | .1 A | 33VDC | 23 | 700mA |

** Figures nominal. Current is 350mA to each of 2 heads (2 heads are required for proper operation, remote or attached).

THERMAL PERFORMANCE DATA

| CATALOG NUMBER | AMBIENT | CID1 | CID1 | SUITABILITY | SUPPLY WIRE |
|----------------|---------|------|------|-------------|-------------|
| EBS23DH | 45°C | T6 | EFG | 0-45°C | 75°C |
| EBSEL1030 | 55°C | T6 | EFG | -40 to 40°C | 75°C |
| EBSHK1030 | 55°C | T6 | EFG | -40 to 40°C | 75°C |

4 Head EBS option:

EBS units are designed for 2 head operation and will provide the lumens noted at right. However, 4 heads can be connected and will operate for 90 Minutes at half the published lumen values. The EBSHK1030 would provide 456 lumens; the EBSEL1030 540 lumens. Instructions for wiring are included with the main EBS unit.

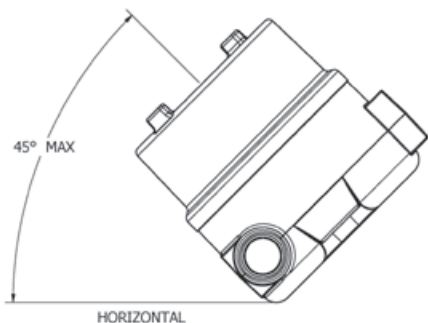

EBSHK Heads can be aimed up to 45 above horizontal – if flush on wall will require spacing out.



LIGHTING

EMERGENCY BATTERY SYSTEM – DIMENSIONS & WEIGHTS

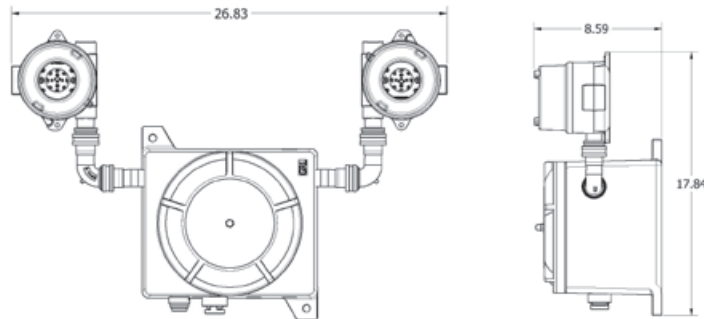

Dimensions - EBS with HK Heads

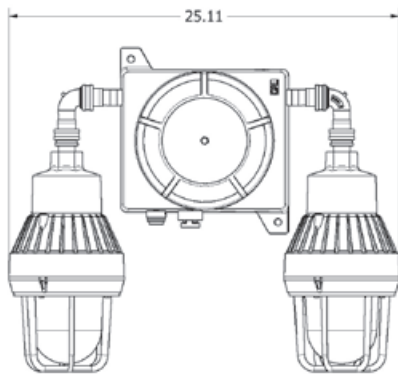

Dimensions - EBS with EL Heads

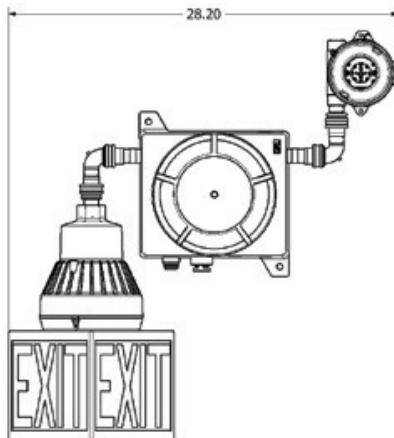

Dimensions - EBS with EL-EXIT & HK Heads

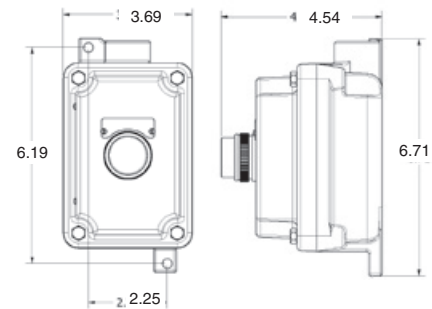

Dimensions - Remote Test Station

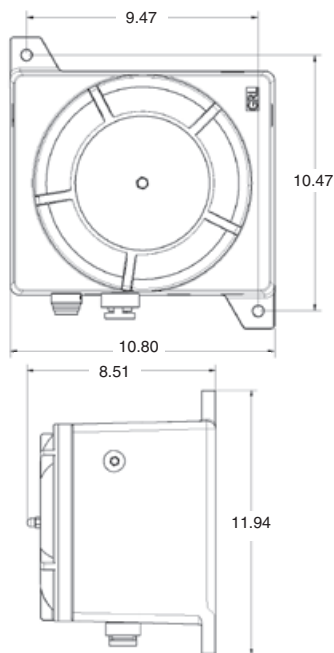

Dimensions - EBS Main Unit

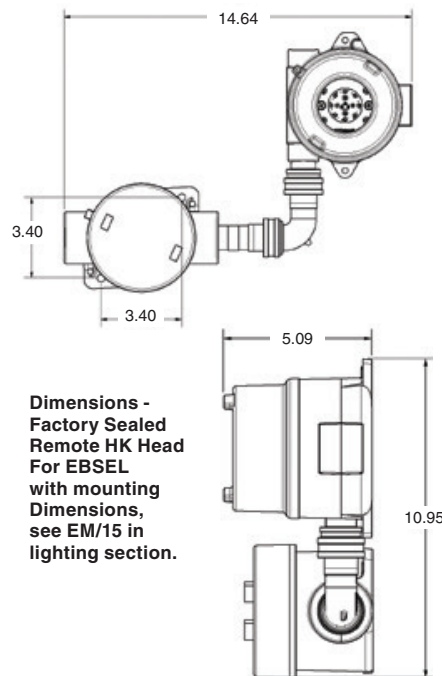

Dimensions -
Factory Sealed
Remote HK Head
For EBSEL
with mounting
Dimensions,
see EM/15 in
lighting section.

| WEIGHTS (SHIPPING) INDIVIDUAL AND COMBINATIONS [Ⓞ] | LBS. |
|---|------|
| EGS23DH Main Unit Only | 36.6 |
| EBSEL1030 Pendant Head Only w/ Fittings Set | 12.3 |
| EBSHK1030 Head Only w/ Fittings Set | 5.0 |
| EBSHK1030-RFSC (or RFSL) | 11.0 |
| EBS-PTT | 3.0 |
| EBS-AHFS Factory Sealed Fittings Set | 0.6 |
| EBS23DH & 1 EBShk w/ Fittings | 41.6 |
| EBS23DH & 2 EBShk w/ Fittings | 46.6 |
| EBS23DH & 1 EBSEL w/ Fittings | 48.9 |
| EBS23DH & 2 EBSEL w/ Fittings | 61.2 |
| EBS23DH & 1 EBSEL & 1 EBShk w/ Fittings | 53.9 |

[Ⓞ] EBSEL Heads ship separately